

Portable Compressors

KAESER
COMPRESSORS

with the world renowned Sigma Profile 

MOBILAIR™ M 56

200 cfm @ 100 psig



NOTE:

The Kaeser M 56 has been upgraded
and is now the Kaeser M 57

210 cfm @ 100 psi 51 BHP

Features and Specifications

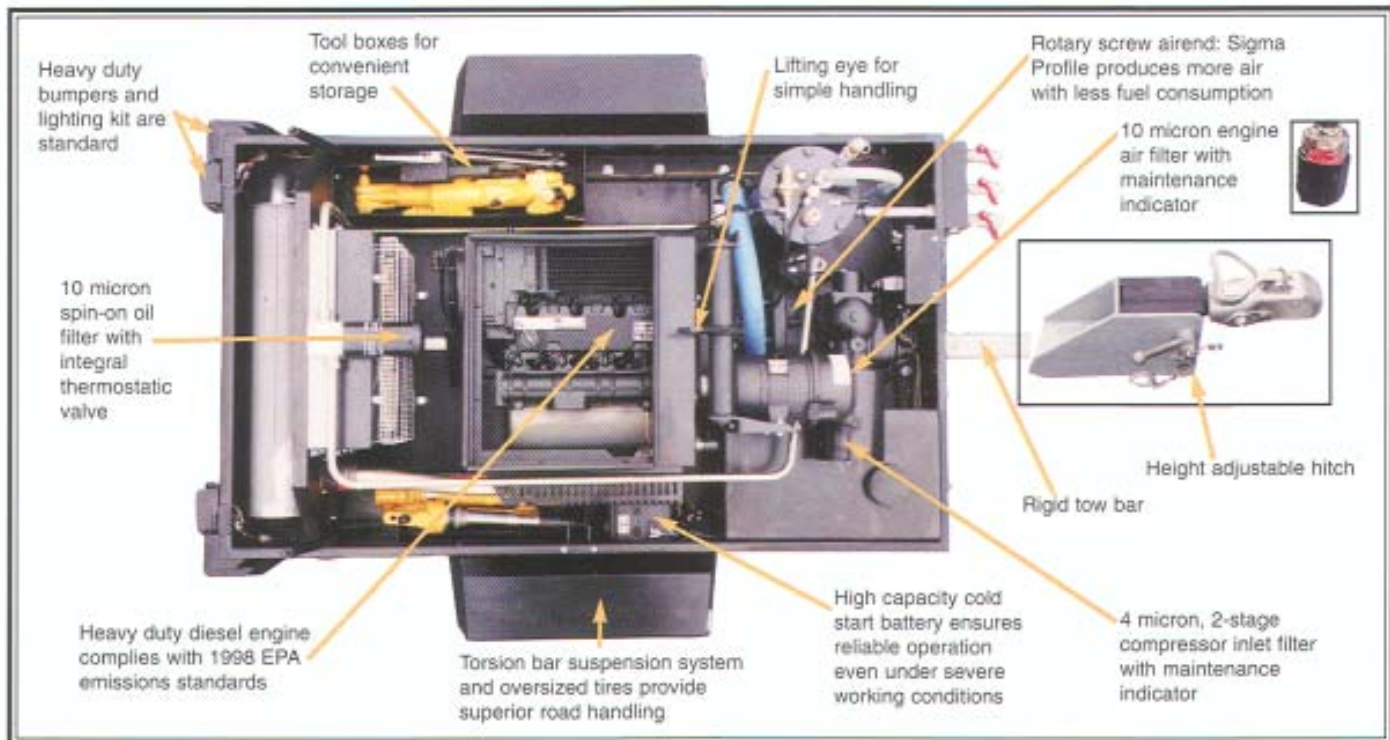

Easy Operation

- Easy to read control panel is well protected under the canopy and visible from the outside
- Large filler neck with overflow protection for safe, easy fueling



Maximum Efficiency and Minimal Maintenance

- Highly efficient cooling system
- Modulating air control matches air demand
- Easy access to all maintenance points
- Efficient Sigma Profile airend reduces fuel consumption

Durable and Quiet

- Heavy duty steel chassis stands up to any work environment
- Fully galvanized canopy protects internal components
- Super soundproofing is standard
- Can be used in ambient temperatures up to 120°F

Accessories and Options

- Other pressures up to 145 psig
- Hose reels, gauge packages, and filtration packages
- Complete line of air tools
- Lubricators and separators
- Stationary units
- Generators

Technical Specifications



Compressor	
Free air delivery	200 cfm
Working pressure	100 psig
Diesel engine	
Make	Deutz F4L 1011F
Power at full load	52 hp
Full load speed	2400 rpm
Off load running speed	1800 rpm
Package	
Fuel tank capacity	18.2 gal.
Weight, dry	2376 lb.
Weight, wet	2552 lb.
Sound level max.	76 dB(A) at 23 ft

Specifications are subject to change without notice.

Vermillion™
and associates

phone 423.505.5948 • fax 800.783.8459
info@vermillionassociates.com • www.vermillionassociates.com

Authorized Distributor:

Vermillion and Associates

2176 Sargent Daly Dr.
Chattanooga, TN 37421

Phone: 423-505-5948

Fax: 800-783-8459

www.vermillionassociates.com

